

# A7000

## Signal Stability Analyser

### Features

- Phase & Frequency analyser
- Frequency range: 3MHz - 919MHz
- Short term stability  $<3 \times 10^{-14}$  at 1sec
- Allan Variance & Spectral Density Measurement
- Optional internal GPS or Rubidium frequency reference
- Allan Variance floor  $<1 \times 10^{-16}$  at 10K seconds
- Compatible with 5MHz or 10MHz external reference
- Compatible with Stable 32 Frequency stability software
- Updateable firmware
- Very high resolution: 100fs single shot
- Sample rate: 100ks/s
- Selectable filters, resolutions & tau's
- Optional phase averaging



### Description

The A7000 is a self contained phase/frequency analyser. Its area of use includes measurement of frequency stability and spectral purity of signal sources from 3MHz to 919MHz. Stability of amplifiers, cables, or other passive devices can be measured. Allan Variance (AV) and Power Spectral Density (PSD) graphs are automatically generated. The design is based on the industry standard DMTD (dual mixer time difference) system. This has been considerably extended to permit much faster sampling rates than is usual. Another unusual feature is that the system is designed to make phase and frequency difference measurements between different input frequencies. It can do this by normalising all phase and frequency measurements to a nominal frequency set on each channel.

### Applications

- Stability analysis of Frequency & Phase
- Relative & absolute counter display of frequency & phase
- Phase noise analysis
- Power spectral density measurement

### Options

- High stability internal OCXO, 5MHz or 10MHz reference
- High stability internal Rubidium oscillator reference
- High stability internal 10MHz GPS reference
- Internal AC line input (90 to 240 VAC)
- Replace internal 128k volatile sample memory with 512k nonvolatile memory

1. Input	
<b>Channel A &amp; B:</b>	
Type	SMA
Impedance	1k Ohms nominal
Frequency Range	3MHz to 200MHz
Input levels	+0dBm to +13dBm
Maximum input	2V RMS
Connector ground	Isolated or grounded
<b>Channel C</b>	
Type	SMA
Impedance	50 Ohm nominal
Frequency Range	100MHz to 919MHz
Input levels	+0dBm to +13dBm
Maximum input	+20dBm
Connector ground	Grounded

2. Output	
<b>Reference Out</b>	
Type	SMA
Impedance	50 Ohms nominal
Frequency	50MHz
Level.	Square wave 3.3VCMOS

External Reference	
Type	SMA
Impedance	1K Ohm nominal
Frequency Range	5MHz or 10MHz
Input levels	+0dBm to +13dBm
Maximum input	+20dBm
Connector ground	Isolated

3. Measurement Modes		
<b>Common measurement parameters</b>		
Down convert ratio (D)	100 to 10,000 in 1,2 5 steps (user entered)	
Intermediate frequency range (IF)	1kHz to 500kHz	
Data sampling rate	1ks/s to 100ks/s (Automatically selected) <b>Note 1</b>	
Nominal frequency (FR)	3MHz to 919MHz (user entered)	
<b>Phase</b>		
Phase Data	Phase A <b>Note 2</b>	single channel mode
	Phase B	single channel mode
	Phase C	single channel mode
	Phase B-A	differential mode
	Phase C-A	differential mode
Phase multiplier (downconvert ratio, D)	100 to 10,000 in 1,2 5 steps	
Phase quantization interval <b>Note 3</b>	55/D ps	
Phase range <b>Note 4</b>	$\pm 2.6214/D$ ms	
Phase averaging: (selectable parameters)	OFF, Exponential, Block, Moving average	
Phase report interval (Tau) <b>Note 5</b>	10us to 100s in 1,2 5 steps	
Phase drift (constant temperature)	<1ps per hour typical < 5ps per day typical	
Phase drift with temperature	<2ps per deg C typical	

**Note 1:** The maximum sampling rate is controlled by the IF frequency. If every positive going zero crossing is time tagged, then the maximum sample rate is 1/IF frequency. The IF frequency is the input frequency divided by the downconverter ratio. The maximum sampling rate is also limited by processing time. The maximum sampling rate is limited to 100k samples/second for 1 channel in operation, and 50k samples/s with 2 channels.

**Note 2:** In modes PhaseA, PhaseB, PhaseC, the Phase is measured relative to the internal reference oscillator. This may be phase locked to an external reference.

**Note 3:** This is the phase quantization step. Actual resolution is limited by internal noise.

**Note 4:** Phase rollover may be optionally corrected.

**Note 5:** Report interval (Tau) limited to 100us to 100s for real time data. Faster report rates are available using internal memories. Report rate cannot be higher than sample rate

Frequency		
Frequency data:	coarse frequency A	single channel mode
	coarse frequency B	single channel mode
	coarse frequency C	single channel mode
	fine frequency A	single channel mode
	fine frequency B	single channel mode
	fine frequency C	single channel mode
	fine frequency B-A	differential mode
	fine frequency C-A	differential mode
Nominal Frequency (FR)	user entered, 3MHz to 919MHz	
Frequency range, coarse modes:	±50% of FR/D	
Frequency range, fine modes	FR ±95Hz	
Frequency resolution coarse modes	181.9uHz (Note 6)	
Frequency resolution, fine modes:	44.4nHz (Note 7)	
Gate time	50us to 100s in 1,2 5 steps	
Frequency display	absolute, or fractional error from FR	
Frequency calculation (Note 8)	reciprocal counter (traditional) or averaging counter	

**Note 6:** This is the frequency quantization step. Actual resolution is limited by internal noise. Quantization step is 18.19E-12 at 10MHz

**Note 7:** This is the frequency quantization step. Actual resolution is limited by internal noise. Quantization step is 4.44E-15 at 10MHz.

**Note 8:** At reciprocal counter takes one time tag at the start and end of the gate time, and calculates the reciprocal of the time tag difference. The averaging counter take multiple time tags during the gate time, and uses them in an average to improve resolution

4. Measurement Resolution	
<b>Fine frequency mode</b>	
RMS resolution (10MHz input to channel A and B, mode B-A, D=1000, averaging counter mode)	
Gate time	RMS Resolution
100us	$<1 \times 10^{-8}$
1ms	$<5 \times 10^{-10}$
10ms	$<1 \times 10^{-11}$
100ms	$<5 \times 10^{-13}$
1s	$<5 \times 10^{-14}$
<b>Phase modes</b> (10MHz input to channel A and B, modes B-A, D=1000, average exponential auto)	
RMS resolution (standard deviation of 1000 measurements)	
Tau	RMS Resolution
100us	$<1 \text{ps}$
1ms	$<500 \text{fs}$
10ms	$<100 \text{fs}$

5. Time Domain Noise Floor (Single channel mode)	
Time domain stability (10MHz input to external reference and B. Mode phase B, D= 1000. Average exponential auto)	
Measured at constant ambient temperature.	
Tau (sample rate)	Allan Variance @
1ms	$<5 \times 10^{-10}$ (1ms)
10ms	$<1 \times 10^{-11}$ (10ms)
100ms	$<5 \times 10^{-13}$ (100ms)
1sec	$<2 \times 10^{-13}$ (1sec)
1sec	$<3 \times 10^{-14}$ (10sec)
1sec	$<5 \times 10^{-15}$ (100sec)
1sec	$<5 \times 10^{-15}$ (1000sec)
1sec	$<5 \times 10^{-15}$ (10000sec)

6. Time Domain Noise Floor (Differential mode)	
Time domain stability (10MHz input to channel A and B. mode phase B-A), D=1000, average exponential auto)	
Measured at constant ambient temperature.	
Tau (sample rate)	Allan Variance @
1ms	$<5 \times 10^{-10}$ (1ms)
10ms	$<1 \times 10^{-11}$ (10ms)
100ms	$<5 \times 10^{-13}$ (100ms)
1sec	$<1 \times 10^{-13}$ (1sec)
1sec	$<1 \times 10^{-14}$ (10sec)
1sec	$<2 \times 10^{-15}$ (100sec)
1sec	$<3 \times 10^{-16}$ (1000sec)
1sec	$<1 \times 10^{-16}$ (10000sec)

## 7. Frequency Domain Noise Floor

Phase noise floor (10MHz input to channels A and B. Mode B-A D=1000, no average) (typical values)

Tau	Phase Noise
20us (D=100)	100Hz - 132 dBc/Hz
	1kHz - 133 dBc/Hz
	10kHz - 134 dBc/Hz
	25kHz - 135 dBc/Hz
100us	1Hz - 124 dBc/Hz
	10Hz - 134 dBc/Hz
	100Hz - 138dBc/Hz
	1kHz - 139 dBc/Hz
	5kHz - 139 dBc/Hz

## 8. Measurement error due to internal spuri

- Input referred self-generated spuria <-100dBc (excludes integer boundary spurs, [Note 9](#))
- Input referred crosstalk spurs (10MHz) to channel A, 10.000010MHz to channel B) less than -100dBc (spur at 10Hz)
- Note: crosstalk spurs will be present at multiples of the input frequency difference

**Note 9:** Integer boundary spurs may generally be avoided by changing down the convert ratio (D), or using the alternative LO mode (command AL). The instrument will warm if integer boundary spurs are within 100kHz of the IF frequency

## 9. Internal sample memory

- 128k sample memory, may be written at full sample rate of 100ks/s
- May be segmented into 2 blocks of 64k, or 4 blocks of 32k, independently written and read

## 10. Others

Mechanical	Available in 1U, 2U (full or half rack cabinet) or bench top case
Power supply	12V DC 10W max

## 11. Options

Option 1	Add universal line power supply (internal)
Option 2	Add internal rubidium reference
Option 3	Add internal GPS reference
Option 4	Replace internal 128k volatile sample memory with 512k non-volatile memory

## Allan Variance floor

A7000 phase measurement channel B – A, Tau = 100ms, 10MHz, average auto.

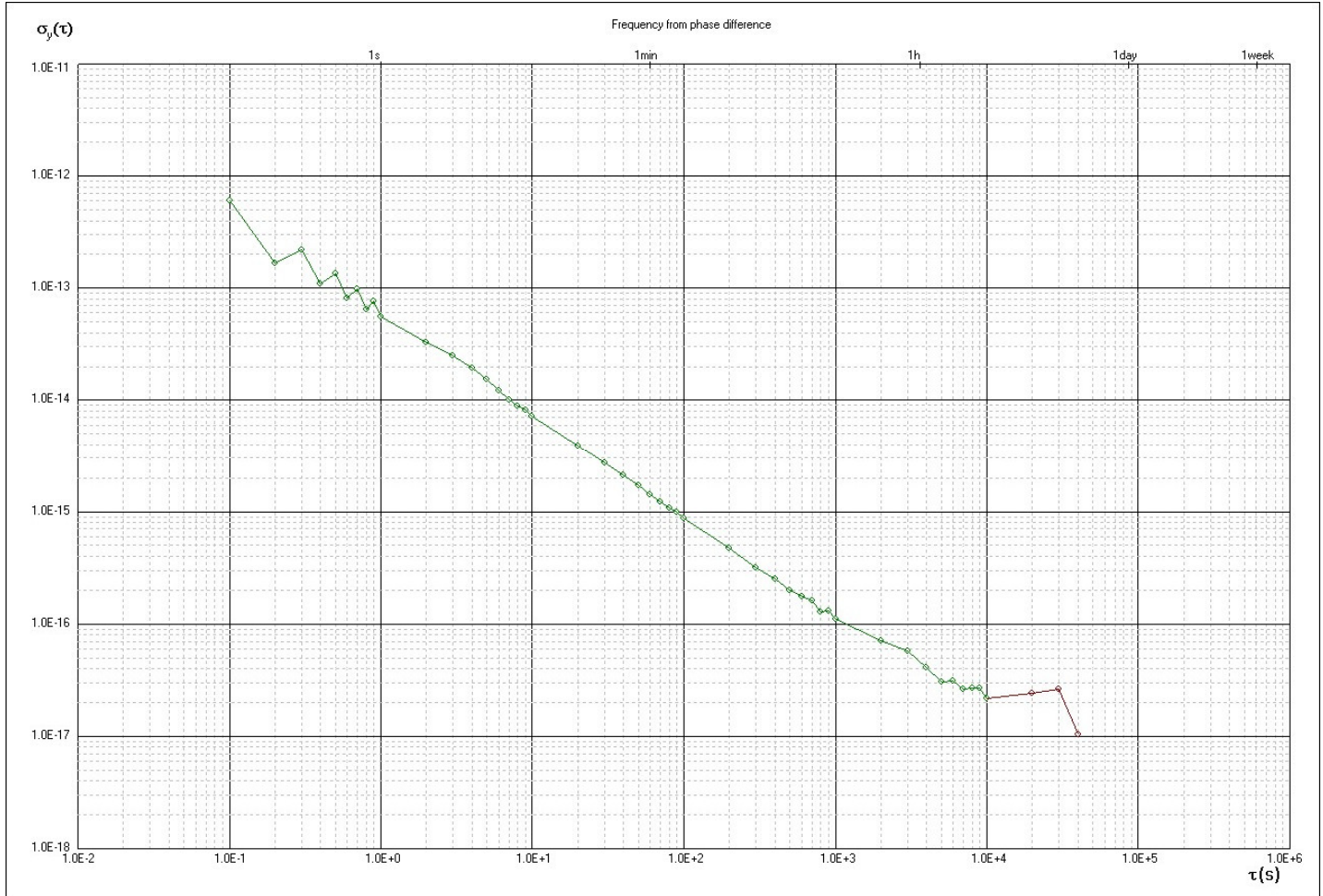

Q

**A7000 overall block diagram**

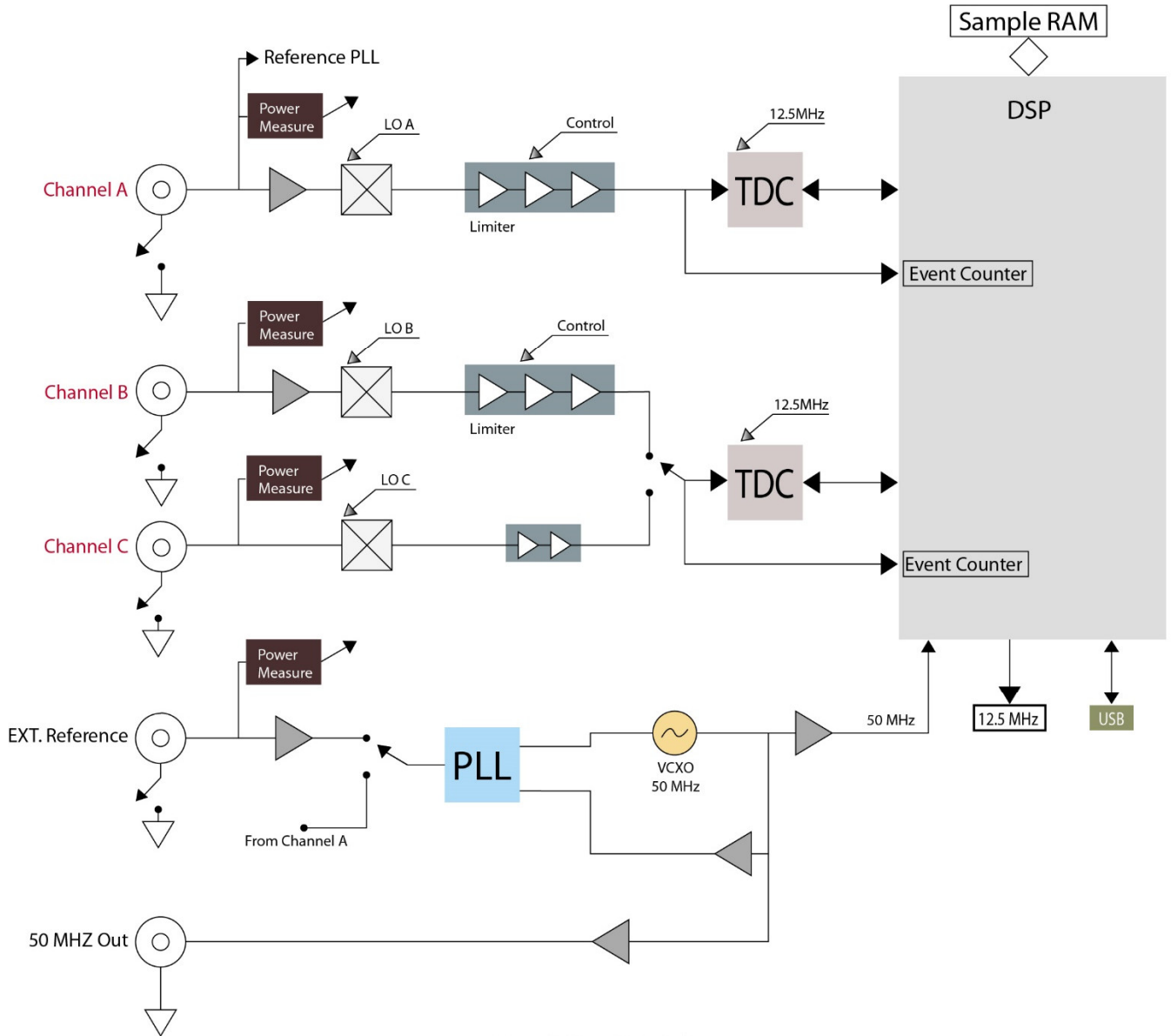

## A7000 bench top case dimensions

A7000 rear view

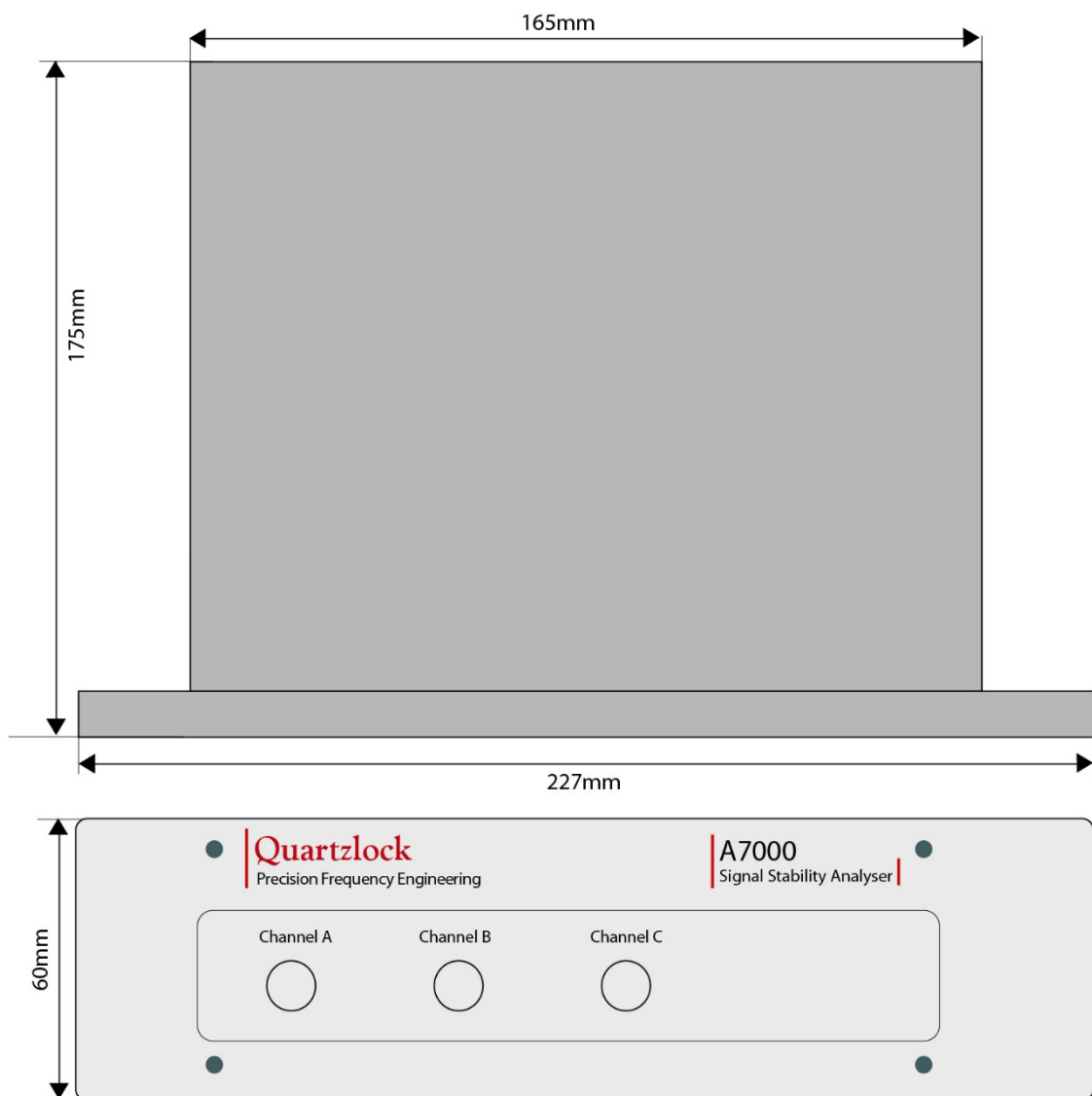

Contact us to configure this product to meet your application.

**Designed and manufactured in the U.K.**

The Quartzlock logo is a registered trademark.

Quartzlock continuous improvement policy: spec subject to change without notice and not part of any contract.

Copyright © 2019. Issue 19.07