



E6-SS

Desk Top Universal Reference Source **USER'S HANDBOOK**

Quartzlock UK Ltd

Gothic, Plymouth Road, Totnes, Devon. TQ9 5LH, England.

Tel: +44 (0) 1803 862062

Web: www.quartzlock.com

E-mail: sales@quartzlock.com

Revision	Date	Description	By
1	12 th Aug 2015	Initial Release	N. Law
2	30 th Aug 2017	Amended Codes/Specification	N. Law

Contents

1	Safety Considerations.....	4
1.1	General.....	4
1.1.1	Before Applying Power.....	4
1.1.2	Before Cleaning.....	4
1.2	Voltage, Frequency and Power Characteristics.....	5
1.2.1	Universal Full Range AC Input Power Adaptor.....	5
1.2.2	Unit Power Requirements.....	5
1.3	Environmental Conditions.....	5
1.3.1	Temperature.....	5
1.4	Cleaning Instructions.....	5
2	Desk Top Universal Reference Source.....	6
2.1	Universal Reference Source.....	6
2.1.1	Introduction.....	6
2.1.2	Technical Description.....	6
3	Operating Procedure.....	12
3.1	Connection to power supply.....	12
3.2	Connection to interface.....	12
3.3	Control codes.....	12
3.3.1	General instructions.....	12
3.4	Calibration.....	13
3.4.1	Internal reference frequency calibration.....	14
3.4.2	RF level accuracy calibration.....	14
3.4.3	Low range RF level interpolation calibration.....	15
3.4.4	AM depth calibration.....	16
4	Specification.....	17
4.1	Frequency.....	17
4.2	Amplitude.....	18
4.3	Modulation.....	18
4.3.1	Internal AM (below 100MHz only).....	18
4.3.2	Internal FM.....	18
4.3.3	External FM.....	19
4.3.4	External FSK.....	19
4.3.5	External ASK.....	19
4.4	Frequency sweep.....	20
4.5	Phase adjust (note 8).....	20
4.6	External reference.....	20
4.7	Power requirements.....	20
4.8	User memories.....	21
4.9	MTBF.....	21
4.10	Environmental.....	21
4.11	EMI.....	21
	Notes.....	21
5	Unit Outline.....	22
6	Accessories.....	23
6.1	Plug Top Supply.....	23
	Appendix A.....	24

1 Safety Considerations

1.1 General

This product and related documentation must be reviewed for familiarisation before operation. If the equipment is used in a manner not specified by the manufacturer, the protection provided by the instrument may be impaired.

1.1.1 Before Applying Power

Verify that the product is set to match the available charger and the correct fuse is installed.

1.1.2 Before Cleaning

Disconnect the product from operating power before cleaning.

WARNING

Bodily injury or death may result from failure to heed a warning. Do not proceed beyond a warning until the indicated conditions are fully understood and met.

CAUTION

Damage to equipment, or incorrect measurement data, may result from failure to heed a caution. Do not proceed beyond a caution until the indicated conditions are fully understood and met.

1.2 Voltage, Frequency and Power Characteristics

1.2.1 Universal Full Range AC Input Power Adaptor

Class II power (no earth)

Overvoltage, short circuit & over temperature protection

GS, UL/cUL & CE approval

Voltage 100 - 240V AC

Frequency 50 - 60Hz

Power characteristics 600mA Max

Output Voltage 15V DC 1.2A

1.2.2 Unit Power Requirements

Input Voltage 11Vdc – 18Vdc

Input Current 600mA max

1.3 Environmental Conditions

1.3.1 Temperature

Operating (ambient) -20°C to +50°C

Charging 0°C to +45°C

Storage -20°C to +40°C

1.4 Cleaning Instructions

To ensure long and trouble free operation, keep the unit free from dust and use care with liquids around the unit.

Be careful not to spill liquids onto the unit. If the unit does get wet, turn the power off immediately and let the unit dry completely before turning it on again.

Never spray cleaner directly onto the unit or let liquid run into any part of it. Never use harsh or caustic products to clean the unit.

2 Desk Top Universal Reference Source

2.1 Universal Reference Source

2.1.1 Introduction

The instrument is a synthesized source optimised for signal purity. A wide range of output frequencies is provided, at output levels between -18 and $+13$ dBm. Various analogue and digital modulation modes are available.

The instrument is powered from a 12V DC supply with a maximum power consumption of 6 watts.

A USB interface is provided. Communication can either use a set of simple control codes, or a front end Windows graphic interface.

2.1.2 Technical Description

A block diagram is shown in [Figure 1](#)

FIG 2 shows the front and rear panel layouts.

The basis of the source is two single chip fractional N synthesizers with built in VCOs.

The first synthesizer (reference synthesizer) generates an intermediate reference frequency between 50MHz and 56.5MHz in steps of 0.5MHz. The reference input to the reference synthesizer is either the internal TCXO at 20MHz, or the external reference input at 10MHz. The reference synthesizer operates in integer mode. The phase comparison frequency is 10MHz. The VCO operates between 2GHz and 2.26GHz. The internal divider is 40.

The second (main) synthesizer generates directly the high range of output frequencies between 100MHz and 3GHz. The internal VCO operates between 1.5GHz and 3GHz, and lower frequencies are generated by binary division using the internal divider. The divider range is 2 to 62. When using the divider, the output is close to a square wave.

The low range of frequencies from 380kHz to 100MHz are generated by external binary dividers with ratios between 2 and 64. ECL dividers are used, with differential outputs.

With predominately square wave outputs from the dividers, the second harmonic is theoretically suppressed, however the third harmonic is only -9.5dBc. Therefore, all outputs are filtered to achieve harmonics at about -40dBc.

On the high range, the filters are monolithic low pass filters switched by FET switches. On the low range, the filters are discrete component filters switched by PIN diodes.

On the high range, amplitude is set by an internal gain control in the main synthesizer chip. This has steps of 1dB.

On the low range, amplitude control is achieved by varying the current in the output emitter followers of the ECL dividers. The setting is made by a 10 bit DAC controlled by the microcontroller.

The main level control is a monolithic FET switched attenuator with a range of 0 to 31.5dB in 0.5dB steps. This is followed by an output amplifier.

The main synthesizer may be operated in integer, fractional, or exact frequency modes. The mode is automatically selected by the software. Integer mode is used when there is an integer relationship between the phase comparison frequency and the VCO frequency. Fractional mode is used when there the VCO frequency is not an integer multiple of the phase comparison frequency. Fractional mode is more susceptible to spurious outputs. The most problematic spurs occur when a multiple of the phase comparison frequency falls within a loop bandwidth (~200kHz) of the VCO frequency. These are called integer boundary spurs. The use of an intermediate reference frequency (50MHz to 56.5MHz in 0.5MHz steps) enables integer boundary spurs to be avoided.

Generally fractional frequency mode does not allow exact decimal relationships between an external reference frequency and an output frequency. For example, a required output frequency of 2.048MHz will actually generate an output frequency of 2.0480000018MHz. This can be a serious problem when generating specific reference frequencies from a frequency standard.

Exact frequency mode is a modification of fractional mode that enables exact decimal relationships with output frequencies entered with a resolution of 1kHz or less on low range, or 3kHz on high range. For any CW frequency, the software attempts to use exact frequency mode. If successful, a front panel LED indicator is lit. In addition, a status bit is set in an interface message.

Various modulation modes are available, described in detail as follows:

AM.

AM is available on low range only. Depth is adjustable from 0 to 40% in steps of 1%. AM modulation frequency is adjustable from 1Hz to 20kHz in steps of 1Hz. AM is achieved by modulation of the low range amplitude control DAC. The modulation frequency is generated by a software DDS with a sampling frequency of 65,57377ks/s

FM (internal)

Internal FM is available with deviations up to 0.5% of the centre frequency, adjustable in 1Hz steps. Modulation frequency is adjustable from 1Hz to 20kHz in 1Hz steps. Internal FM is achieved by direct modulation of the synthesizer fractional divider. The modulation offsets are generated by a software DDS with a sampling frequency of 65,57377ks/s. The offsets to the fractional divider have 16-bit quantization.

As no baseband filter is used after the software DDS, aliased copies of the modulation spectrum will be present at multiples of the sampling frequency. These are typically - 50dB relative to the main response.

FM (external)

DC coupled external FM is available by supplying a suitable modulation waveform to the external modulation input BNC socket on the rear panel. The input range is ± 1 Volt for calibrated deviations, and ± 1.25 V clipping level. The input impedance is 1kohm.

The input waveform is sampled at a 40ks/s rate using a 12bit ADC. The result is then scaled by the selected deviation, and is used to directly modulate the synthesizer fractional divider. As no baseband filter is used, the modulation spectrum will repeat at multiples of the sampling frequency, typically at a level of -50dB relative to the main response.

FSK (external)

Frequency shift keying is available by applying a logic input to the external modulation input on the rear panel. The logic levels are TTL or 3.3V CMOS. A logic 0 produces a negative frequency shift, and a logic 1 a positive shift. The total frequency shift is that programmed for internal FM deviation. i.e., a programmed deviation of 10kHz produces a frequency shift of ± 5 kHz. The maximum baud rate is about 35kbaud. If the maximum rate is exceeded, data bits will be skipped.

ASK (external)

Amplitude shift keying is available by applying a logic input to the external modulation input on the rear panel. The logic levels are TTL or 3.3V CMOS. A logic 0 gives the attenuated level, and a logic 1 the full level. The shift is applied relative to the CW RF level. i.e., if a CW level of 10dBm is programmed, then an ASK shift of 10dB results in a low level of 0dBm, and a high level of 10dBm. If the low level is less than -18dBm , then the low level will use the carrier disable function, which will give a low level equal to the carrier disable level, typically -80dBm . The maximum baud rate for ASK is about 60kbaud.

SWEEP

A flexible frequency sweep mode is provided. This is controlled with three parameters, start frequency, stop frequency, and sweep time. The start and stop frequency may be any frequency within the total operating range of 380kHz to 3GHz. The stop frequency must be greater than the start frequency. The sweep time must be between 10ms and 50 seconds. The number of points will be automatically calculated as sweep time divided by 100us, or 1000 points maximum. Band changes will occur as the sweep crosses band edges. These band changes will result in a short amplitude glitch lasting typically 200us. Fast sweeps across band edges should be avoided. A sync pulse is available at the rear panel modulation input. This occurs at the start of each sweep, and has a high level of 2.4V, and a duration of about 30us.

PHASE ADJUST

The phase adjust mode is only useful if two signal source units are used. If these are locked to the same external reference using a power splitter, then the relative phase between the two outputs may be adjusted if both units are set to the same frequency. Note that exact frequency mode cannot be used, and will be disabled automatically. This means that the output frequency will not have an exact decimal relationship to the external reference.

The external reference input on the rear panel accepts a 10MHz sine wave reference. The external reference should be at a level of 7dBm to 13dBm for optimum phase noise. The input impedance is 100ohms. The presence of the external reference is detected automatically, and if present an LED is lit on the front panel. The external reference replaces the internal TCXO reference, rather than phase locking the internal reference. This means that the external reference phase noise will directly affect the output phase noise over the range of the loop bandwidth, approximately 0Hz to 200kHz.

One of the design objectives was that the source could be used without the interface connected. This can be useful when the source is used to supply a few frequencies that are not often changed. In order to achieve this, 5 user memories are provided. One of these is the power on memory, automatically recalled at power on, and the other 4 are user memories which may be recalled using a front panel control.

Power on memory.

The power on memory stores CW frequency, RF level, and all modulation parameters (except phase adjust parameters). However, the modulation mode is always set to CW on power up. Therefore, the power on memory can only be used to store a CW frequency.

The power on memory is refreshed every 1.193 hours, and is set to the current instrument status, irrespective of whether the interface is connected or not.

User memories.

The user memories can only be refreshed with the current instrument status using an interface command. A user memory can be recalled using an interface command, or by using the front panel pushbutton. This cycles through all four user memories. The use of a memory is indicated by a lit LED on the front panel. If the instrument status is changed using an interface command, the memory LEDs are turned off to show that the memories may not reflect the current instrument status. The user memories store the CW frequency, RF level, modulation parameters, and the modulation mode.

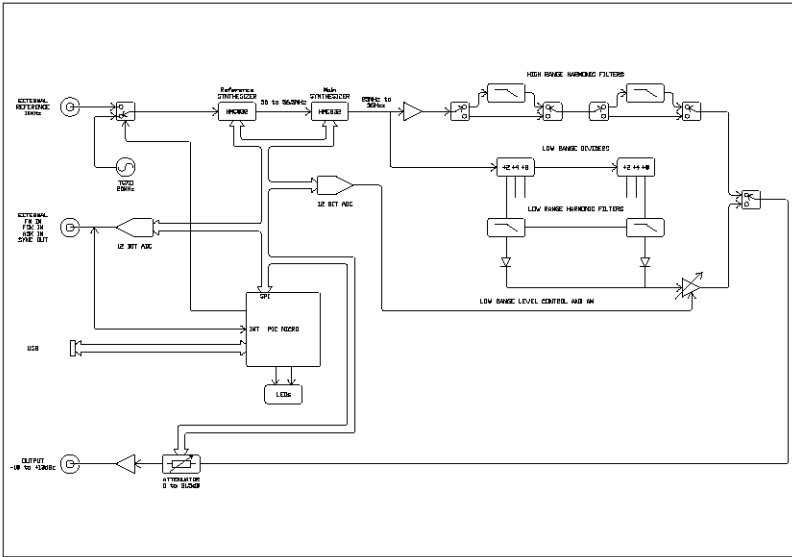

Figure 1

3 Operating Procedure

3.1 Connection to power supply

The supplied line adapter can be used to power the instrument from AC line power.

Alternatively, any good quality DC supply may be used. DC supply voltage is 10 to 15V, and power consumption about 6W. At 12V, current is about 500mA. The centre pin of the power connector is positive.

WARNING

Reverse polarity may cause damage.

3.2 Connection to interface

The USB interface uses a FT230X interface chip made by FTDI. The first connection of the instrument should result in the usual Windows dialog, and the driver should be found on the internet automatically. If this does not happen, the correct driver to suit the operating system in use should be downloaded from the FTDI website, and installed.

The interface driver will create a virtual port, which should appear in the port list accessed by Device Manager. A terminal program such as HyperTerm can then be used to control the instrument using the control codes. Alternatively, the custom GUI supplied can be used. This will have its own operating instructions.

3.3 Control codes

This section covers in detail the use of the interface control codes.

3.3.1 General instructions

All control codes use upper case. All commands start with two characters. Most commands have an interrogative form, where a “?” is appended to the command. Some two character commands immediately initiate an action without further input. With some commands, a third character immediately initiates an action without further input. A successful input always results in a carriage return response. An incorrect command or sequence results in an

“!” and a carriage return. (Note that when using HyperTerm, the option to append a line feed to a received carriage return should be used).

Examples:

FR?	Interrogates current CW frequency and frequency step
FRI	Increments current CW frequency by frequency step
EU	update EEPROM with all user and calibration data

There are two types of data entry used by commands:

Those which expect a fixed length hexadecimal string, and do not require a terminator character such as a carriage return or enter. Examples:

SM1 Store instrument status to user memory 1

Those which expect a variable length decimal or character string. A decimal string may contain special characters such as sign, decimal point, and multiplier, and terminates with a carriage return (enter). The string is always preceded by a space. Examples:

FR (space) 10.23M (carriage return)	enters 10.23MHz
MM (space) FSK (carriage return)	sets modulation mode to FSK
RF (space) -18.0 (carriage return)	sets RF level to -18dBm
FST (space) 20k (carriage return)	sets sweep time to 20 secs

The following frequency and time multipliers are accepted:

k, K, M, G

Some commands accept a standard floating point string, which may include “e” or “E”, however it is never necessary to use the exponent form.

A full list of available commands is given in [Appendix A](#). Some of these commands are intended for development or debug. In this section the commands likely to be used frequently by the user are described.

3.4 Calibration

All calibration is closed case. There are no adjustments on the PC board.

The following adjustment procedures are possible:

- a) Internal reference frequency calibration

- b) RF level accuracy calibration
- c) Low range RF level interpolation calibration
- d) AM depth calibration

3.4.1 Internal reference frequency calibration

Procedure:

Connect the instrument RF output to a frequency counter with an internal or external reference of accuracy better than 1 in 10^8 .

Set RF level to 10dBm, and CW frequency to 100MHz.

Allow 1 hour warm up from power on.

The TCXO tuning is accessed using the SS command. SS? will return the synthesizer status bytes. The fourth byte is the internal reference tune. New tune bytes should be entered using the SSTdd command until the output frequency is within $1E-7$ of 100MHz (± 10 Hz).

Finally the new tune value should be saved to EEPROM using the EU command.

3.4.2 RF level accuracy calibration

For this procedure a power meter with recorder output is used. A suitable power meter is the HP435B, HP436A, or HP437B with appropriate sensor type 8482A.

Procedure:

The sensor is connected directly to the instrument RF output connector using a suitable adapter.

The recorder output from the power meter is connected to the rear panel modulation input.

Initial settings for the instrument are: RF level 13dBm

The power meter should be calibrated, and its CF setting adjusted to the individual power sensor calibration for 50MHz. It is not possible to adjust the power meter calibration during the automatic procedure. It is now necessary to get a reading of 13.0dBm ± 0.1 dB on the power meter. This can be done by trying various centre frequencies on the instrument, or by connecting the power meter to another adjustable RF source of any frequency. The objective is to relate the recorder output to a measured

The two keys “0” and “1” switch the power control increment by 1dB. The objective is to adjust the calibration table so the increment measured on the power meter is also 1dB. The calibration table is incremented and decremented using the “+” and “-” keys (on the numeric keypad).

The attenuation increment should be set to 0dB, and the power meter reading noted. The power control increment is then set to 1dB, and the calibration value varied until the power meter reading has decreased by 1dB also.

Key “N” selects the next frequency, and the above procedure is repeated. The final frequency is 60MHz.

At the end of the calibration, press key “S” to save the calibration table in EEPROM. Finally press key “E” to exit the routine.

3.4.4 AM depth calibration.

This calibration uses a modulation meter, or other modulation analyser. Suitable types are Racal 9009 or Marconi TF2304. A modulation analyser such as HP8901 can also be used.

Procedure:

Set the instrument to AM, 30% depth, 10MHz. RF level 13dBm.

Connect the modulation meter to the instruments RF output.

Send the following command:

SSB03 activates board test 3

Use the “N” key to select the first calibration frequency (1MHz)

The modulation meter should be reading approximately 30% AM.

Using the “+” and “-” keys, adjust the reading to 30% \pm 2%

Repeat for all 7 calibration frequencies

Press key “S” to save the calibration table in EEPROM

Press key “E” to exit the routine.

4 Specification

4.1 Frequency

Coverage: 1MHz - 3GHz
(Under range to 380kHz)

Bands:

Range	Band no	Frequency <small>(note 1)</small>	N <small>(note 2)</small>
H	4	1.493GHz to 3.0GHz	1
H	3	755MHz to 1.493GHz	2
H	2	369MHz to 755MHz	4
H	1	184.5MHz to 369MHz	8
H	0	100MHz to 184.5MHz	16
L	6	49.8MHz to 100MHz	32
L	5	25.2MHz to 49.8MHz	64
L	4	12.6MHz to 25.2MHz	128
L	3	6.29MHz to 12.6MHz	256
L	2	3.15MHz to 6.29MHz	512
L	1	1.57MHz to 3.15MHz	1024
L	0	1MHz to 1.57MHz	2048

Frequency resolution:

Band H4	3Hz
Band H3	1.5Hz
Otherwise	1Hz

Frequency accuracy:

Internal reference	$\pm 1 \text{ ppm} \pm \text{aging}$
External reference	$\pm \text{resolution}$
Exact Frequency Mode (EFM)	no error <small>(note 3)</small>

Spectral purity:

Harmonics

2nd and 3rd < -30dBc (typically -40dBc)

Subharmonics

Band L6	<-60dBc
Otherwise	none

Non harmonics

> 1kHz from carrier <-70dBc (typically <-80dBc)

Phase noise (10kHz offset), external reference

Band H4 2GHz	-100dBc/Hz
Band H3 1GHz	-106dBc/Hz
Band H2 500MHz	-112dBc/Hz
Band H1 250MHz	-118dBc/Hz
Band H0 125MHz	-122dBc/Hz

Residual FM (300Hz - 3kHz, ext. reference)

Band H4 2GHz	<1.8Hz RMS
Band H3 1GHz	<0.8Hz RMS
Band L6 100MHz	<0.15Hz RMS

4.2 Amplitude

Coverage: -18.0 - +13.0 dBm into 50ohms

Resolution:

H ranges	0.5dB
L ranges	0.1dB

Accuracy:

H ranges	±1dB
L ranges	±0.5dB

Maximum output (over-range, typical): 16dBm

4.3 Modulation

4.3.1 Internal AM (below 100MHz only)

Type:	Stepped sine wave, Sample rate 65.57377ks/s Quantization 12 bit
Frequency:	1Hz - 10kHz, step size 1Hz
Depth:	0 - 30%
Depth accuracy:	±10% of setting

4.3.2 Internal FM

Type:	Stepped sine wave
Sample rate	65.57377ks/s

Quantization	16bit
Frequency:	1Hz - 20kHz
Step size	1Hz
Deviation:	0Hz - 0.5% of centre frequency
Step size	1Hz

4.3.3 External FM

Input:	Bipolar 1V peak for calibrated deviation
Input impedance:	1kohm
Sampling rate:	40ks/s
Quantization:	12bit
Frequency:	DC - 20kHz
Deviation:	0Hz - 0.083% of centre frequency
Step size	1Hz

4.3.4 External FSK

Input:	TTL/3.3V CMOS
Data rate:	35kbaud maximum
Frequency shift:	± 0 Hz - 0.25% of centre frequency
Step size	1Hz
Type	unfiltered 2 level Phase continuous

4.3.5 External ASK

Input:	TTL/3.3V CMOS
Data rate:	60kbaud maximum
Amplitude shift:	
13dBm output	0.5dB - 31.5dB

Or

Low range	80dB min ^(note 7)
High range	60dB min

4.4 Frequency sweep

Type:	linear, up
Start frequency:	any, within frequency range
Stop frequency:	any, within frequency range. Must be > start frequency
Sweep time:	10ms - 50s in 1ms steps
No of points	sweep time/100us or max 1000
Dwell time:	100us min
Sync pulse:	TTL, 30us, at sweep start

4.5 Phase adjust (note 8)

Phase increment:	1 - 360degrees in 1degree steps
Increment accuracy:	±0.5 degrees

4.6 External reference

Frequency:	10MHz ±0.1ppm ^(note 4)
Amplitude:	-10 to +15dBm ^(note 5)
Input Impedance:	100ohm
Spectral purity:	Spurii ^(note 6) <-100dBc
Phase noise:	-150dBc/Hz at 10kHz offset

4.7 Power requirements

Voltage:	12V DC ±10%
Supply current:	550mA max

4.8 User memories

4 user memories plus power on memory.

User memories may be programmed or recalled over USB interface, or may be selected in sequence using front panel push button.

4.9 MTBF

100,000 hours

4.10 Environmental

RoHS

4.11 EMI

Compliant to

FCC Part 15 Class B

Notes

Note 1: Frequency bands shown are approximate.

Note 2: N is the division factor. Phase noise and spuri generally reduce by $20 \cdot \log N$ dB

Note 3: Exact frequency mode is possible for most frequencies with greater than 1kHz resolution. In exact frequency mode the CW frequency is an exact multiple of the external reference frequency.

Note 4: Other external reference frequencies are available to special order.

Note 5: For minimum phase noise, amplitude of external reference should be 7dBm to 13dBm sine wave

Note 6: External reference should have very low spuri, as spuri within the loop bandwidth of about 200kHz will appear multiplied in amplitude on the output.

Note 7: If RF level minus ASK amplitude shift is less than -18 dBm, ASK mode will use a carrier disable function which will increase the amplitude shift to a minimum of the values specified.

Note 8: Exact frequency mode cannot be used in phase adjust mode, and will be disabled.

5 Unit Outline

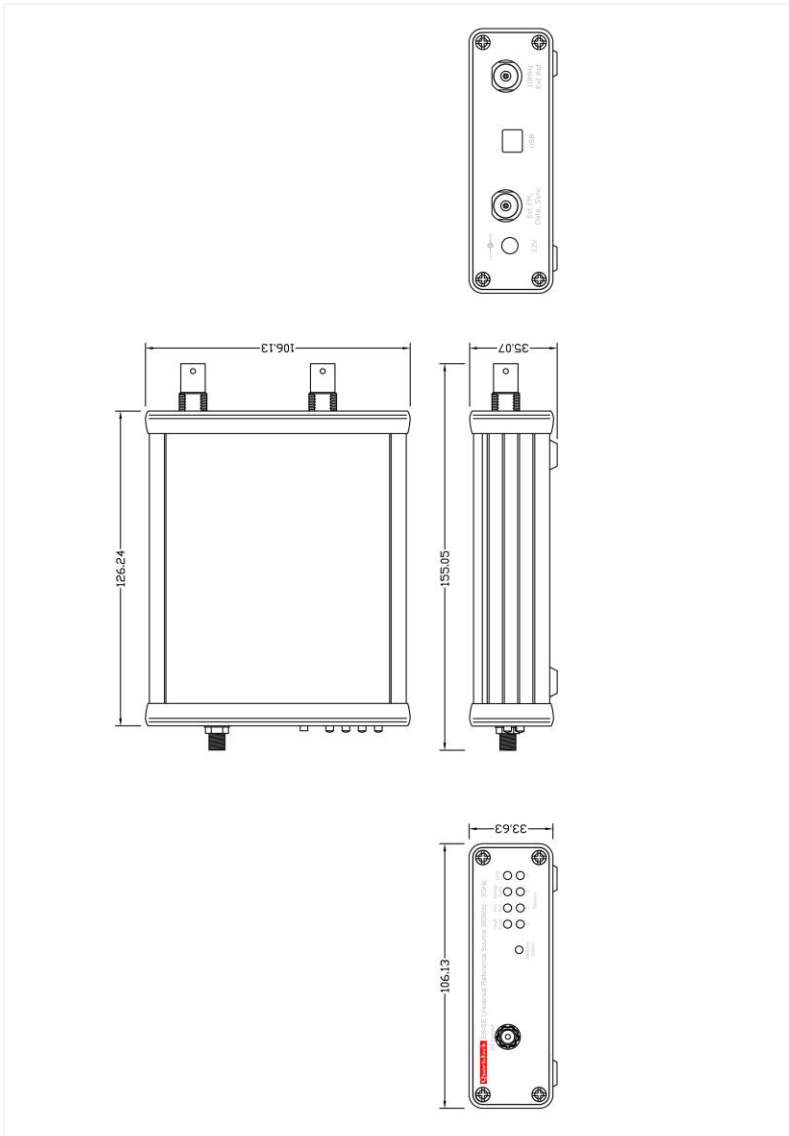

6 Accessories

6.1 Plug Top Supply

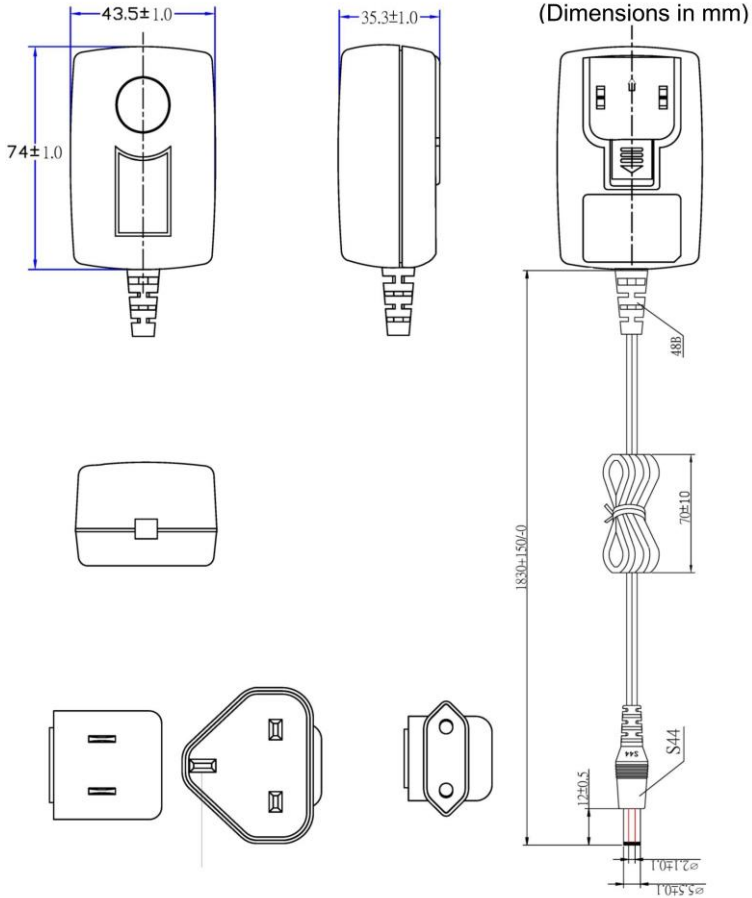

Appendix A

RS232 control codes (all values following command or returned from the microcontroller are hexadecimal unless stated)

* = backed up in EEPROM

FR	Frequency	
	FR?	Returns current centre frequency, frequency step aaaaaaaaa dddddddd
	aaaaaaaaa	is centre frequency in Hz (decimal)
	dddddddd	is frequency step in Hz (decimal)
*	FR (space) (string) (carriage return)	Inputs new centre frequency
*	FRS (space) (string) (carriage return)	Inputs new frequency step
	FRI	Increments current centre frequency by frequency step
	FRD	Decrements current centre frequency by frequency step
MM	Modulation Mode	
	MM?	Returns modulation mode byte aa
	aa	is modulation mode byte: bits set: bit0: Phase Adjust mode bit1: ASK mode (R/W) bit2: Sweep mode(R/W) bit3: FSK mode(R/W) bit4: Ext FM mode(R/W) bit5: Internal FM mode(R/W) bit6: Internal AM mode(R/W) bit7: Carrier Off
	MMBaa	Inputs a new modulation mode byte
	MM(space)(string)(carriage return)	Inputs new modulation mode. String is one of: PA Phase adjust mode ASK External ASK mode FS Sweep mode FSK External FSK mode EXT External FM mode FM Internal FM mode AM Internal AM mode OFF Carrier off

FM Frequency Modulation Parameters

FM? Returns FM parameters:

aaaaaaaaa bbbbbbbbbb

aaaaaaaaa is decimal frequency deviation in Hz

bbbbbbbbb is decimal frequency modulation rate in Hz

* FMD (space) (string) (carriage return) Inputs new deviation

* FMR (space) (string) (carriage return) Inputs new rate

AM Amplitude Modulation Parameters

AM? Returns AM parameters:

aaaaaaaaa bbbbbbbbbb

aaaaaaaaa is decimal modulation frequency in Hz

bbbbbbbbb is decimal modulation depth in percent

* AMR (space) (string) (carriage return) Inputs new modulation frequency

* AMD (space) (string) (carriage return) Inputs new depth in percent

AS Amplitude Shift Keying (ASK) Parameters

AS? Returns ASK parameter:

aaa

aaa is amplitude shift in dB

* AS (space) (string) (carriage return) Inputs new amplitude shift

FS Frequency Sweep Parameters

FS? Returns FS parameters:

aaaaaaaaa bbbbbbbbbb ccccccc dddddddd eeeeeeeee

aaaaaaaaa is sweep start frequency in Hz

bbbbbbbbb is sweep stop frequency in Hz

ccccccc is sweep time in ms

ddddddd is no of points

eeeeeeeeee is frequency step in Hz

* FSS (space) (string) (carriage return) Inputs new start frequency

* FSE (space) (string) (carriage return) Inputs new stop frequency

* FST (space) (string) (carriage return) Inputs new sweep time in ms

PA	Phase Adjust	
	PA?	Returns phase adjustment parameters
	aaaa	is phase increment in degrees
*	PA (space) (string) (carriage return)	Inputs new phase increment
	PAI	Increments phase
	PAD	Decrements phase
RF	RF level	
	RF?	Returns RF level -15.0 to +13.0 dBm
*	RF (space) (string) (carriage return)	Inputs new RF level
OS	Overall Status	
	OS?	Returns overall status bytes:
	aa bbb ccc ddd eee fff gggggggg hhhhhhhhhh iiiiiiiiii	
	aa	is mode byte: bits set:
		bit0: Phase adjust mode
		bit1: ASK mode (R/W)
		bit2: Sweep mode(R/W)
		bit3: FSK mode(R/W)
		bit4: Ext FM mode(R/W)
		bit5: Internal FM mode(R/W)
		bit6: Internal AM mode
		bit7: Carrier Off
	bbb	is range (decimal)
	ccc	is band (decimal)
	ddd	is internal divider (decimal)
	eee	is low range divider (decimal)
	fff	is integer divider (decimal)
	gggggggg	is fractional divider (decimal)
	hhhhhhhhh	is phase detector frequency (main synth)(decimal)
	iiiiiiiiii	is VCO frequency (main synth) (decimal)

SS	Synthesizer Status		
	SS?	Returns synthesizer parameters	
		aa bb cc dd ee ff gggg	
	aa	is lock status	bits set: bit0 exact frequency mode bit1 integer mode bit2 external reference bit3 reference synthesizer locked bit4 main synthesizer locked
	bb	is RFpower byte (high range) (hex) valid range 00h to 0Bh	
	cc	is RFpower byte (low range) (hex) valid range 00h to FFh	
	dd	is Internal reference tune. Valid range 00h to FFh	
	ee	is board test number	
	ff	is special status	bits set: bit0 mute off during autocal bit1 autocal off bit2 bypass high range power control bit3 bypass low range power control bit4 allow over range on RF level bit5 NU bit6 NU bit7 NU
*	gggg	is running time (hex) unit 1 hour	
	SSPbb	Inputs a new RFpower (high range)	
	SSLcc	Inputs a new RFpower (low range)	
	SSTdd	Inputs a new internal reference tune	
	SSBee	Inputs a new board test	
*	SSSff	Inputs a new special status	
SM	Store user memory		
*	SMa	Stores status to user memory a	a = 0, 1, 2, 3
RM	Recall user memory		
	RMa	Recalls status from user memory a	a = 0, 1, 2, 3
EU	EEPROM update (calibration tables and power up state)		
ED	load EEPROM and RAM with default values		
	EDa	Loads EEPROM with default a	a = 0, 1, 2

ER	EEPROM read	
	ERCaaaabb	Returns bb bytes from starting address aaaa as ASCII characters
	ERNaaaabb	Returns bb bytes from starting address aaaa as hexadecimal numbers (character pairs)
DR	dump RAM	
	DRaaaabb	Returns bb bytes from starting address aaaa as hexadecimal numbers
EW	EEPROM write	
	EWCaabbbcccc-----c	Writes bb characters to starting address aaaa. Correct number of characters must be included in string.
	EWNaabbbcccc-----c	Writes bb bytes to starting address aaaa. Character pairs cc etc. are interpreted as hexadecimal numbers.
RR	Read Registers	
	Reads synthesizer registers	
BP	Breakpoint Table	
	Reads breakpoint table	

Command Nos:

OS	0	FR	1	ED	2	FM	3
RI	4	EU	5	ER	6	EW	7
DR	8	RR	9	SS	10	FS	11
BP	12	SM	13	RF	14	RM	15
MM	16	PA	17	AM	18	AS	19

ERRORS:

- 1 Programmed frequency outside range 380kHz to 3GHz
- 2 FM or AM rate outside permitted range of 0Hz to 20kHz
- 3 FM deviation outside permitted range of 0Hz to 0.5% of CW frequency
- 4 Frequency Step outside permitted range of 0Hz to 100MHz
- 5 Sweep Start outside permitted range of 1MHz to 2.999999GHz
- 6 Sweep Stop outside permitted range of 1.000001MHz to 3.000000GHz
- 7 Sweep Time outside permitted range of 10ms to 50s
- 8 RF level outside permitted range of -18.0dBm to + 13.0dBm
- 9 Phase Increment outside permitted range of 1.0 degrees to + 360.0 degrees
- 10 AM depth outside permitted range of 0% to 40%
- 11 Reference Synthesizer unlocked
- 12 Main Synthesizer unlocked
- 13 ASK level shift outside permitted range 0dB to 31.5dB

FREQUENCY BANDS:

	FREQ	RANGE	BAND
>=	1.493172224GHz	1	4
>=	754.974720MHz	1	3
>=	369.098752MHz	1	2
>=	184.549376MHz	1	1
>=	100.000001MHz	1	0
>=	49.807360MHz	0	6
>=	25.165824MHz	0	5
>=	12.582912MHz	0	4
>=	6.291456MHz	0	3
>=	3.145728MHz	0	2
>=	1.572864MHz	0	1
>=	1MHz	0	0